

# Single Chip 3-Axis Magnetic Sensor

## QMC6983

The QMC6983 is a single chip three-axis magnetic sensor. This surface-mount, small sized chip has integrated magnetic sensors with signal condition ASIC, targeted for applications such as compassing, map rotation, gaming and personal navigation in mobile and personal hand-held devices.

The QMC6983 is based on our state-of-the-art, high resolution, magneto-resistive technology. Along with custom-designed 16-bit ADC ASIC, it offers the advantages of low noise, high accuracy, low power consumption, offset cancellation and temperature compensation. QMC6983 enables 1° to 2° compass heading accuracy. The I<sup>2</sup>C serial bus allows for easy interface.

The QMC6983 is in a 1.6x1.6x0.75mm<sup>3</sup> surface mount 12-pin leadless grid array (LGA) package.

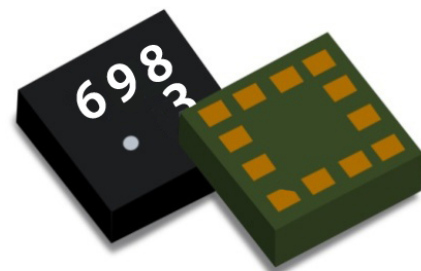

### FEATURES

- ▶ 3-Axis Magneto-Resistive Sensors in a 1.6x1.6x0.75 mm<sup>3</sup> Land Grid Array Package (LGA), guaranteed to operate over an extended temperature range of -40 °C to +85 °C.
- ▶ 16 Bit ADC With Low Noise AMR Sensors Achieves 2 milli-Gauss Field Resolution
- ▶ Wide Magnetic Field Range (±20 Gauss)
- ▶ Temperature Compensated Data Output and Temperature Output
- ▶ I<sup>2</sup>C Interface with Standard and Fast Modes.
- ▶ Built-In Self-Test
- ▶ Wide Range Operation Voltage (2.16V To 3.6V) and Low Power Consumption (75µA)
- ▶ Lead Free Package Construction
- ▶ Software And Algorithm Support Available

### BENEFIT

- ▶ Small Size for Highly Integrated Products. Signals Have Been Digitized And Calibrated.
- ▶ Enables 1° To 2° Degree Compass Heading Accuracy , Allows for Pedestrian Navigation and LBS Applications
- ▶ Maximizes Sensor's Full Dynamic Range and Resolution
- ▶ Automatically Maintains Sensor's Sensitivity Under Wide Operating Temperature Range
- ▶ High-Speed Interfaces for Fast Data Communications. Maximum 200Hz Data Output Rate
- ▶ Enables Low-Cost Functionality Test After Assembly in Production
- ▶ Compatible with Battery Powered Applications
- ▶ RoHS Compliance
- ▶ Compassing Heading, Hard Iron, Soft Iron, and Auto Calibration Libraries Available

## CONTENTS

1	INTERNAL SCHEMATIC DIAGRAM.....	3
1.1	Internal Schematic Diagram .....	3
2	SPECIFICATIONS AND I/O CHARACTERISTICS.....	3
2.1	Product Specifications.....	3
2.2	Absolute Maximum Ratings.....	4
2.3	I/O Characteristics .....	5
3	PACKAGE PIN CONFIGURATIONS.....	5
3.1	Package 3-D View .....	5
3.2	Package Outlines.....	6
4	EXTERNAL CONNECTION.....	7
4.1	Dual Supply Connection.....	7
4.2	Single Supply connection.....	7
4.3	Mounting Considerations .....	8
4.4	Layout Considerations .....	8
5	BASIC DEVICE OPERATION.....	9
5.1	Anisotropic Magneto-Resistive Sensors .....	9
5.2	Power Management.....	9
5.3	Power On/Off Time .....	9
5.4	Communication Bus Interface I <sup>2</sup> C and Its Addresses.....	10
5.5	Internal Clock.....	10
5.6	Temperature Compensation.....	10
5.7	Temperature Output.....	11
6	MODES OF OPERATION.....	11
6.1	Modes Transition .....	11
6.2	Description of Modes .....	11
7	Application Examples .....	13
7.1	Continuous Mode Setup Example .....	13
7.2	Measurement Example .....	13
7.3	Self-test Example.....	13
7.4	Standby Example.....	14
7.5	Soft Reset Example .....	14
8	I <sup>2</sup> C COMMUNICATION PROTOCOL.....	14
8.1	I <sup>2</sup> C Timings .....	14
8.2	I <sup>2</sup> C R/W Operation .....	14
9	REGISTERS .....	16
9.1	Register Map .....	16
9.2	Register Definition.....	16

# 1 INTERNAL SCHEMATIC DIAGRAM

## 1.1 Internal Schematic Diagram

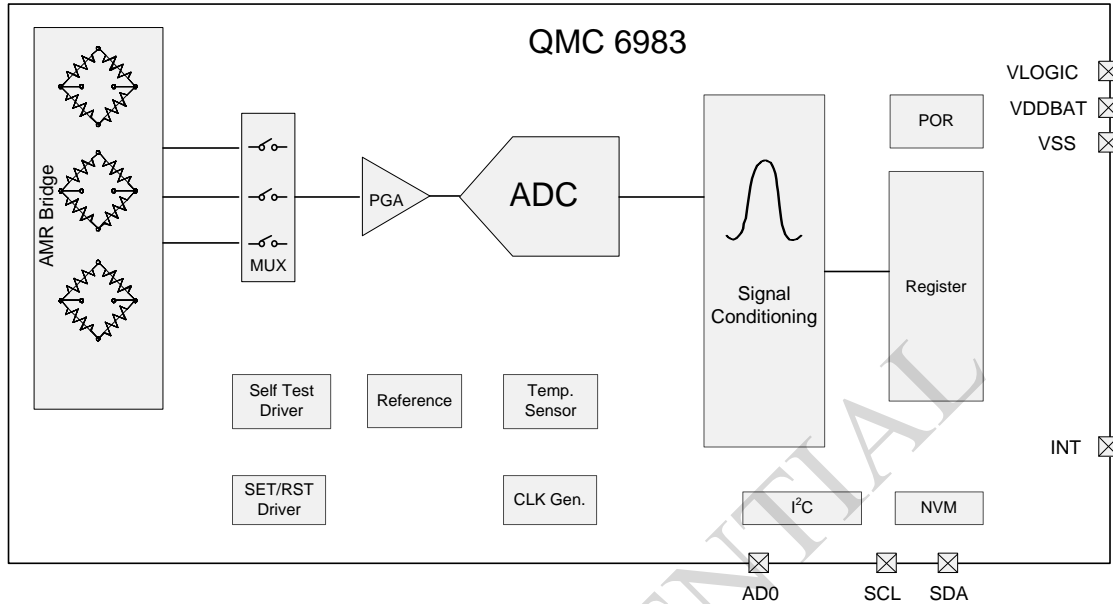

Figure 1. Block Diagram

Table 1. Block Function

Block	Function
AMR Bridge	3 axis magnetic sensor
MUX	Multiplexer for sensor channels
PGA	Programmable gain amplifier for sensor signals
ADC	16 bit Analog-to-Digital converter
Signal Conditioning	Digital blocks for magnetic signal calibration and compensation
I <sup>2</sup> C	Interface logic data I/O
NVM	Non-Volatile memory for calibrated parameters
Self-Test Driver	Internal driver to generate self-test stimulus
SET/RST Driver	Internal driver to initialize magnetic sensor
Reference	Voltage/Current reference for internal biasing
Clock Gen.	Internal oscillator for internal operation
POR	Power on reset
Temperature Sensor	Temperature sensor for internal sensitivity /offset compensation, and temperature output

# 2 SPECIFICATIONS AND I/O CHARACTERISTICS

## 2.1 Product Specifications

Table 2. Specifications (\* Tested and specified at 25°C except stated otherwise.)

Parameter	Conditions	Min	Typ	Max	Unit
Supply Voltage	VDDBAT	2.16		3.6	V
I/O Voltage	VLOGIC	1.65		3.6	V
Standby Current	Total Current on VDDBAT and VLOGIC		3		μA

Parameter	Conditions	Min	Typ	Max	Unit	
Continuous Mode Current	Low/High Power Mode (OSR=64 or 512)	ODR = 10Hz		75/100		μA
		ODR = 50Hz		150/250		μA
		ODR = 100Hz		250/450		μA
		ODR = 200Hz		450/850		μA
Peak Current in Active State	Peak Current on VDDBAT and VLOGIC During Measurement		2.6		mA	
Sensor Field Range	Full Scale	-20		+20	Gauss	
Dynamic Output Field Range	Programmable	±2		±20	Gauss	
Sensitivity <sup>[1]</sup>	Field Range = ±2G		10000		LSB/G	
	Field Range = ±8G		2500		LSB/G	
	Field Range = ±12G		1666		LSB/G	
	Field Range = ±20G		1000		LSB/G	
Linearity (Best fit linear curve)	Field Range = ±2G (X-Y) (Z Axis)		0.2 1.0		%FS	
	Field Range = ±8G (X-Y) (Z Axis)		0.6 1.5		%FS	
Hysteresis	All Ranges (X-Y Axis) (Z Axis)		0.3 2		%FS	
Cross Axis Sensitivity	Cross field = 1 gauss, Applied = ±2 gauss		0.1		%/G	
Offset			±10		mG	
Sensitivity Tempco	Ta = -40°C~85°C		±0.05		%/°C	
Temperature Sensor Sensitivity	Ta = -40°C~85°C		100		LSB/°C	
Digital Resolution	Change with Gain	0.1		1.0	mGauss	
Field Resolution	Standard deviation 100 Data, FS ±2G (X-Y) (Z)		2 20		mGauss	
Output Data Rate	Programmable. 10Hz/50Hz/100Hz/200Hz	10		200	Samples /sec	
Self-Test	Field Range = ±8G (X-Y) (Z) Field Range = ±20G (X-Y) (Z)		2600 -6500 1000 -2500		LSB	
X-Y-Z Orthogonality	Sensitivity Directions		90±1		degree	
Operating Temperature		-40		85	°C	
ESD	HB Model	2000			V	
	Machine Model	200				

Note [1]: Sensitivity is calibrated at zero field, it is slightly decreased at high fields.

## 2.2 Absolute Maximum Ratings

**Table 3. Absolute Maximum Ratings (Tested at 25°C except stated otherwise.)**

Parameter	MIN.	MAX.	Units
VDDBAT	-0.3	5.4	V
VLOGIC	-0.3	5.4	V
Storage Temperature	-40	125	°C
Exposed to Magnetic Field (all directions)		50000	Gauss
Reflow Classification	MSL 3, 260 °C Peak Temperature		

## 2.3 I/O Characteristics

Table 4. I/O Characteristics

Parameter	Symbol	Pin	Condition	Min.	TYP.	Max.	Unit
Voltage Input High Level 1	$V_{IH1}$	SDA, SCL		$0.7 \cdot V_{LO}$ GIC		$V_{LOGIC}$ +0.3	V
Voltage Input Low Level 1	$V_{IL1}$	SDA, SCL		-0.3		$0.3 \cdot V_{LO}$ GIC	V
Voltage Output High Level	$V_{OH}$	INT	Output Current $\geq -100\mu A$	$0.8 \cdot V_{LO}$ GIC			V
Voltage Output Low Level	$V_{OL}$	INT, SDA	Output Current $\leq 100\mu A$ (INT) Output Current $\leq 1mA$ (SDA)			$0.2 \cdot V_{LO}$ GIC	V

## 3 PACKAGE PIN CONFIGURATIONS

### 3.1 Package 3-D View

Arrow indicates direction of magnetic field that generates a positive output reading in normal measurement configuration.

<QMC6983>

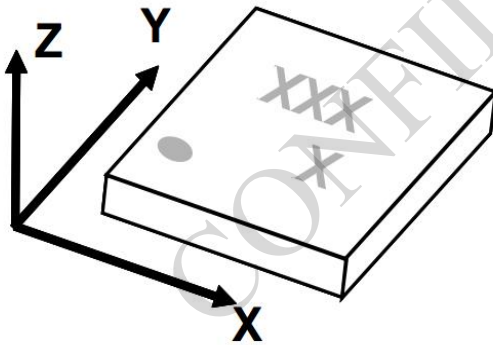

Figure 2. Package 3-D View

Table 5. Pin Configurations

PIN No.	PIN NAME	I/O	Power Supply	TYPE	Function
1	INT	O	VLOGIC	CMOS	Data Ready Interrupt Output
2	NC				Not Connected
3	SCL	I	VLOGIC	CMOS	I <sup>2</sup> C Clock
4	SDA	I/O	VLOGIC	CMOS	I <sup>2</sup> C Data
5	RSV				Keep This PIN Floating
6	VLOGIC	-	-	Power	Digital Power Supply
7	NC				Not Connected
8	NC				Not Connected
9	NC				Not Connected
10	AD0	I	VDDBAT	CMOS(Analog)	I <sup>2</sup> C Address

# QMC6983

11	VSS	-	-	Power	Ground PIN
12	VDDBAT	-	-	Power	Analog Power Supply

## 3.2 Package Outlines

### 3.2.1 Package Type

LGA (Land Grid Array)

### 3.2.2 Package Size:

1.6mm (Length)\*1.6mm (Width)\*0.75mm (Height)

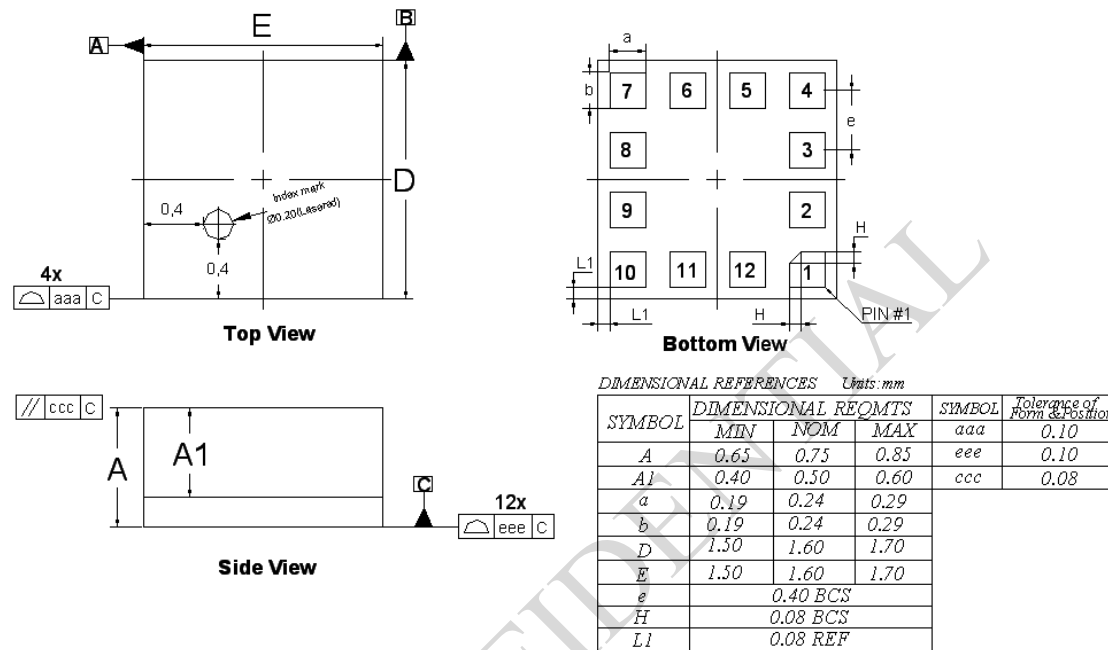

Figure 3. Package Size

### 3.2.3 Marking:

Tracking code: X<sub>1</sub>X<sub>2</sub>X<sub>3</sub>

X<sub>1</sub>: Year code

X<sub>2</sub>X<sub>3</sub>: Lot code

X<sub>4</sub>: Product number (Digit 1 means QMC6983)

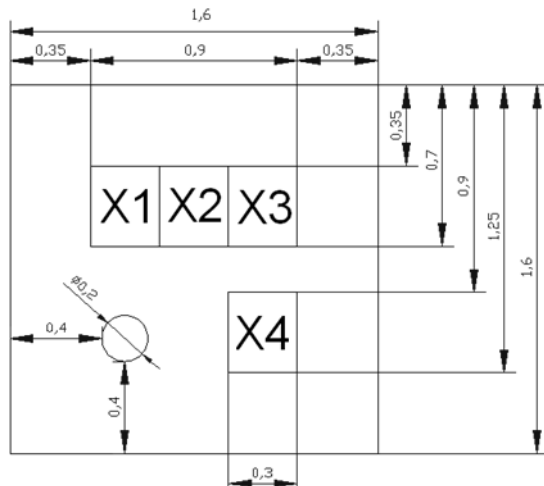

Figure 4. Chip Marking

## 4 EXTERNAL CONNECTION

### 4.1 Dual Supply Connection

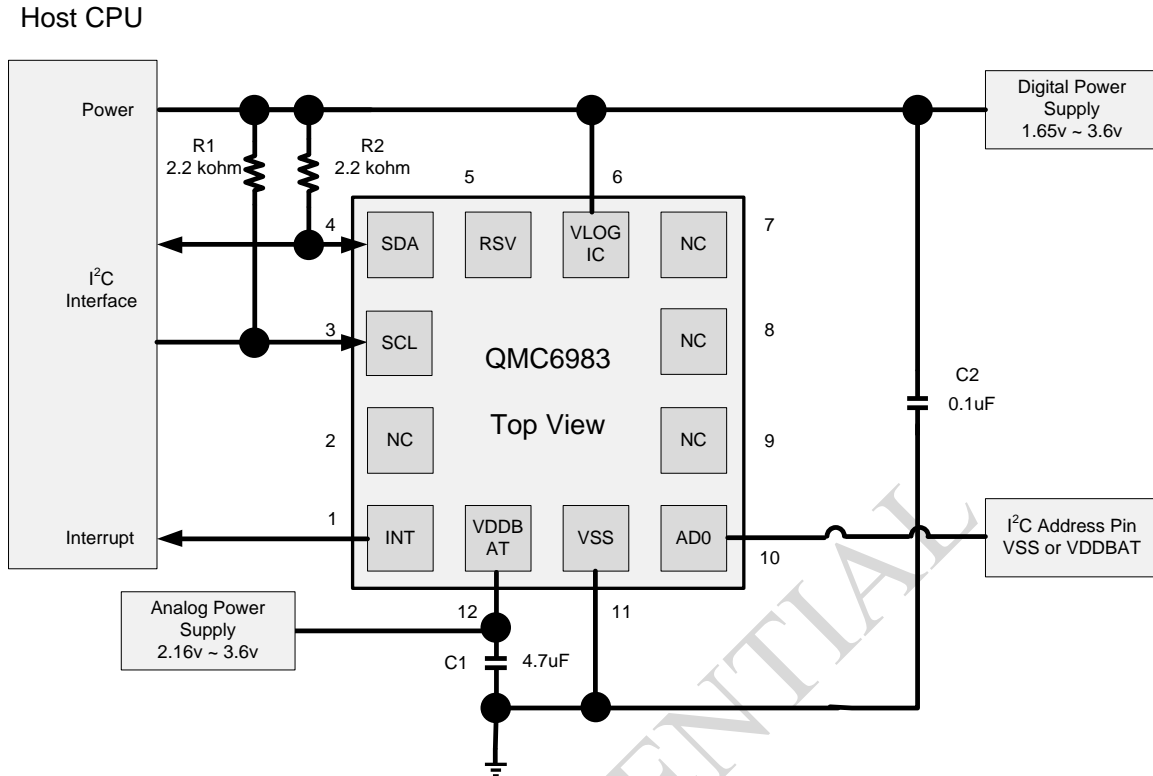

Figure 5. Dual Supply Connection

### 4.2 Single Supply connection

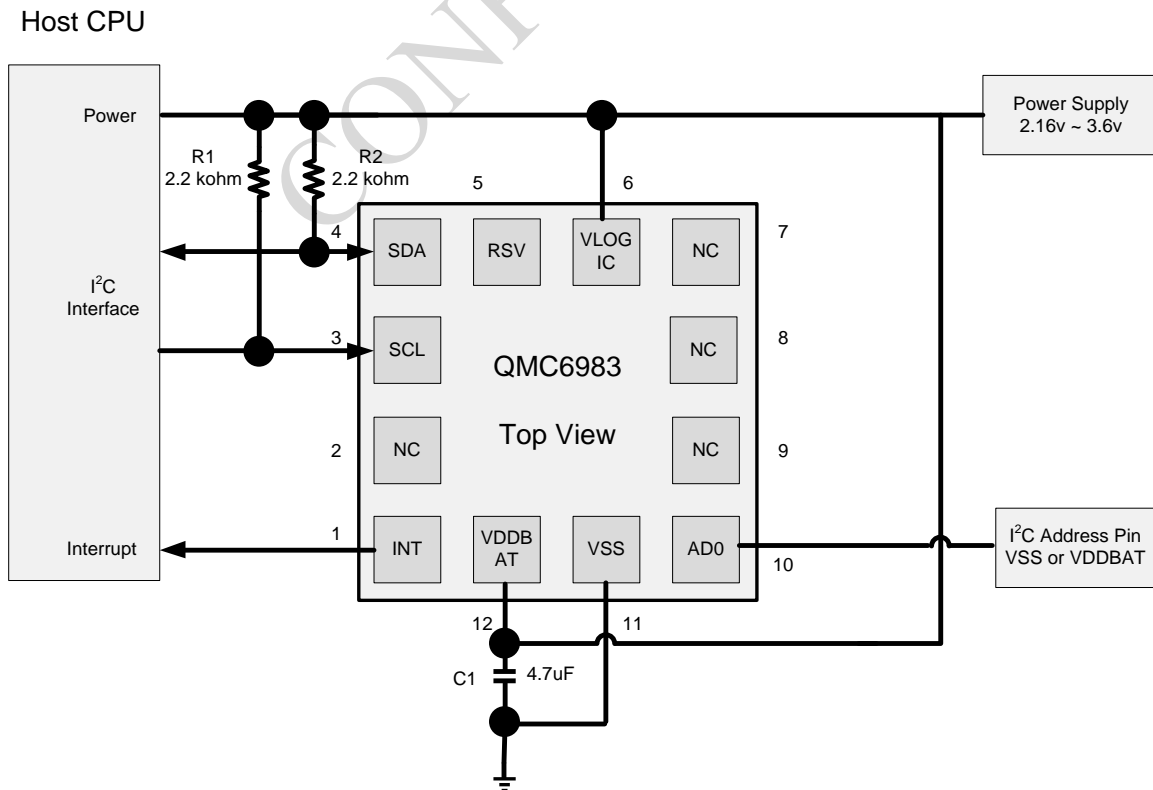

Figure 6. Single Supply Connection

### 4.3 Mounting Considerations

The following is the recommend printed circuit board (PCB) footprint for the QMC6983. Due to the fine pitch of the pads, the footprint should be properly centered in the PCB.

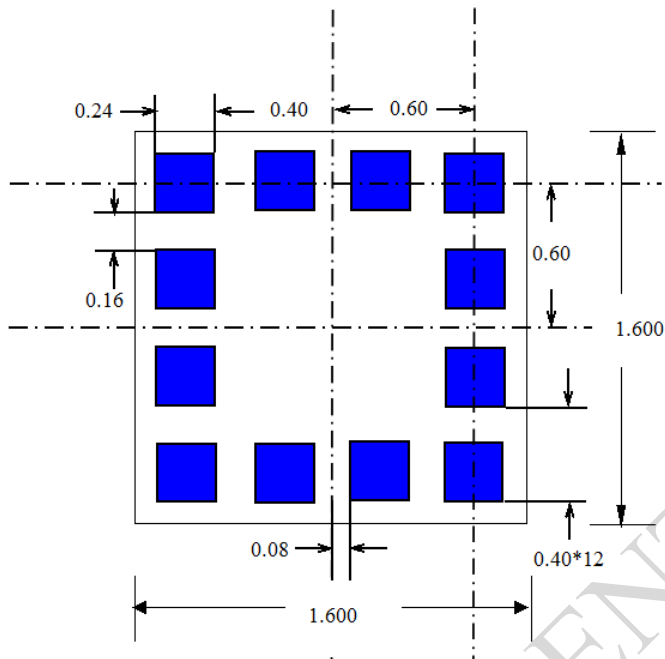

Figure 7. QMC6983 PCB footprint

### 4.4 Layout Considerations

Besides keeping all components that may contain ferrous materials (nickel, etc.) away from the sensor on both sides of the PCB, it is also recommended that there is no conducting copper line under/near the sensor in any of the PCB layers.

#### 4.4.1 Solder Paste

A 4 mil stencil and 100% paste coverage is recommended for the electrical contact pads.

#### 4.4.2 Reflow Assembly

This device is classified as MSL 3 with 260°C peak reflow temperature. As specified by JEDEC, parts with an MSL 3 rating require baking prior to soldering, if the part is not kept in a continuously dry (< 10% RH) environment before assembly. Reference IPC/JEDEC standard J-STD-033 for additional information.

No special reflow profile is required for QMC6983, which is compatible with lead eutectic and lead-free solder paste reflow profiles. QST recommends adopting solder paste manufacturer's guidelines. Hand soldering is not recommended.

#### 4.4.3 External Capacitors

The external capacitors C1 should be ceramic type with low ESR characteristics. The exact ESR value is not critical, but values less than 200 milli-ohms are recommended. Reservoir capacitor C1 is nominally 4.7 µF in capacitance. Low ESR characteristics may not be in many small SMT ceramic capacitors (0402), so be prepared to up-size the capacitors to gain low ESR characteristics.



## 5 BASIC DEVICE OPERATION

### 5.1 Anisotropic Magneto-Resistive Sensors

The QMC6983 magneto-resistive sensor circuit consists of tri-axial sensors and application specific support circuits to measure magnetic fields. With a DC power supply is applied to the sensor two terminals, the sensor converts any incident magnetic field in the sensitive axis directions to a differential voltage output.

The device has an offset cancellation function to eliminate sensor and ASIC offsets. It also applies a self-aligned magnetic field to restore magnetic state before each measurement to ensure high accuracy. Because of these features, the QMC6983 doesn't need to calibrate every time in most of application situations. It may need to be calibrated once in a new system or a system changes a new battery.

### 5.2 Power Management

There are two power supply pins to the device. VDDBAT provides power for all the internal analog and digital functional blocks. VLOGIC provides power for digital I/O and logic. It is possible to work with VLOGIC equal to VDDBAT, the single supply mode, or with VLOGIC lower than VDDBAT, the dual supply mode.

The device should turn-on both power pins in order to operate properly. When the device is powered on, all registers are reset by POR, then the device transits to the standby mode and waits for further commands.

Table 6 provides references for four power states. Transitions between power state 2 and power state 3 are prohibited, due to leakage current concerns.

**Table 6: Power States**

Power State	VDDBAT	VLOGIC	Power State description
1	0V	0V	Device Off, No Power Consumption
2	0V	1.65v~3.6v	Device Off, Unpredictable Leakage Current on VLOGIC due to Floating Node.
3	2.16v~3.6v	0	Device Off, Same Current as Standby Mode
4	2.16v~3.6v	1.65v~3.6v	Device On, Normal Operation Mode, Enters Standby Mode after POR

### 5.3 Power On/Off Time

After the device is powered on, some time periods are required for the device fully functional. The external power supply requires a time period for voltage to ramp up (PSUP), it is typically 50 milli-second. However it isn't controlled by the device. The Power –On –Reset time period (PORT) includes time to reset all the logics, load values in NVM to proper registers, enter the standby mode and get ready for analogy measurements. The power on/off time related to the device is in Table 7.

**Table 7. Time Required for Power On/Off**

Parameter	Symbol	Condition	Min.	Typ.	Max.	Unit
POR Completion Time	PORT	Time Period After VDDBAT and VLOGIC at Operating Voltage to Ready for I <sup>2</sup> C Command and Analogy Measurement.			350	uS
Power off Voltage	SDV	Voltage that Device Considers to be Power Down.			0.2	V
Power on Interval	PINT	Time Period Required for Voltage Lower Than SDV to Enable Next POR	100			uS

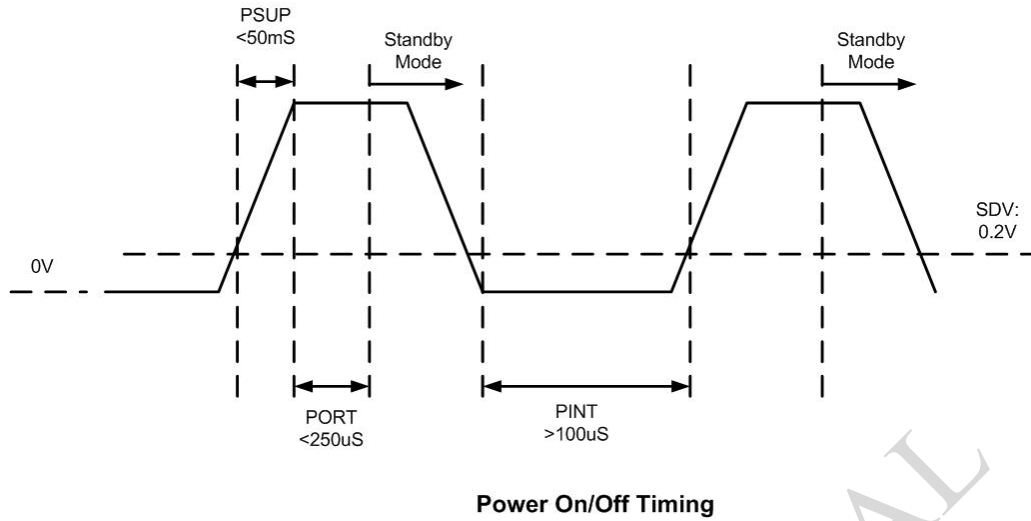

**Figure 8. Power On/Off Timing**

### 5.4 Communication Bus Interface I<sup>2</sup>C and Its Addresses

This device will be connected to a serial interface bus as a slave device under the control of a master device, such as the processor. Control of this device is carried out via I<sup>2</sup>C.

This device is compliant with I<sup>2</sup>C -Bus Specification, document number: 9398 393 40011. As an I<sup>2</sup>C compatible device, this device has a 7-bit serial address and supports I<sup>2</sup>C protocols. This device supports standard and fast speed modes, 100kHz and 400kHz, respectively. External pull-up resistors are required to support all these modes.

There are two I<sup>2</sup>C addresses selected by connecting pin 10 (AD0) to VSS or VDDBAT. The first six MSB are hardware configured to “000110” and the LSB can be configured by AD0.

**Table 8. I<sup>2</sup>C Address Options**

AD0 (pin 10)	I <sup>2</sup> C Slave Address(HEX)	I <sup>2</sup> C Slave Address(BIN)
Connect to VSS	0CH	0001100
Connect to VDDBAT	0DH	0001101

If more I<sup>2</sup>C address options are required, please contact factory for metal layer changes.

### 5.5 Internal Clock

The device has an internal clock for internal digital logic functions and timing management. This clock is not available to external usage.

### 5.6 Temperature Compensation

Temperature compensation of the measured magnetic data is enabled by default at the factory. Temperature measured by the built-in temperature sensor will be used to compensate the magnetic sensor’s sensitivity

changes due to temperatures. The compensated magnetic sensor data is placed in the Output Data Registers automatically.

## 5.7 Temperature Output

QMC6983 has a built-in temperature sensor, it can provide temperature reading for other applications. The output is placed in Temperature Output Registers (07H and 08H). The temperature is calibrated for its sensitivity.

# 6 MODES OF OPERATION

## 6.1 Modes Transition

The device has three different operational modes, controlled by register (09H), mode bits. The main purpose of these modes is for power management and self-assessment. The modes can be transitioned from one to another, as shown below, through I<sup>2</sup>C commands of changing mode bits. The default mode is Standby.

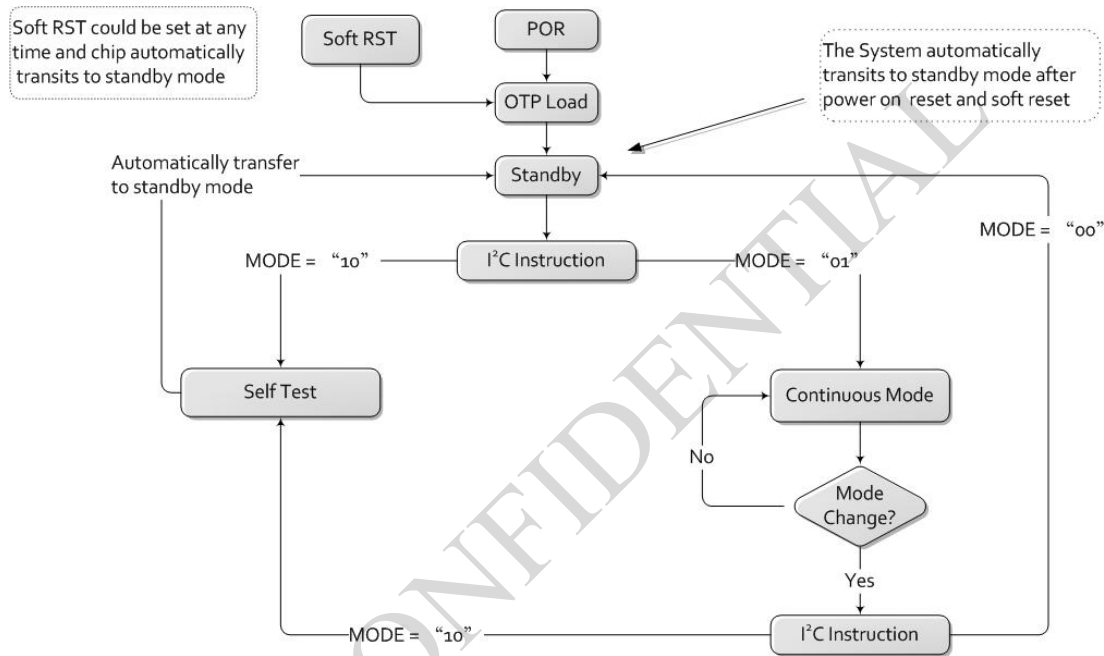

Figure 9. Modes Transition

## 6.2 Description of Modes

### 6.2.1 Continuous-Measurement Mode

During the continuous-measurement mode (mode bits= 01), the magnetic sensor continuously makes measurements and places measured data in data output registers. The field range (or sensitivity) and data output rate registers are also located in the control register (09H), they should be set up properly for your applications in the continuous-measurement mode.

For example, if the application requires output data rate 50Hz, the ODR bit in control register (09H) should be 01. If the field range is +/-12 Gauss, the RNG =10.

The over sample rate is optional for you to use. The default is OSR=00, if your application has enough resolution and need low power consumption, you may reduce OSR to a lower number, such as OSR=10 (128) or OSR =11 (64).

In the continuous-measurement mode, the magnetic sensor data are automatically compensated for offset and temperature effects. The gains are calibrated in the factory.

#### 6.2.1.1 Normal Read Sequence

Complete magnetometer data read-out can be done as follow steps.

# QMC6983

- ✧ Check INT pin or by polling DRDY in Register 06H
- ✧ Read DRDY in Register 06H (if polling, it's unnecessary)  
 DRDY: Data ready ("1") or Not ("0").  
 DOR: Any data has been missed ("1") or not ("0")
- ✧ Read measured data, if any of the six data register is accessed, DRDY and DOR turn to "0".
- ✧ Data protection, if any of the six data register is accessed, data protection starts. During Data protection period, data register cannot be updated until the last bits 05H (ZOUT [15:8]) have been read.

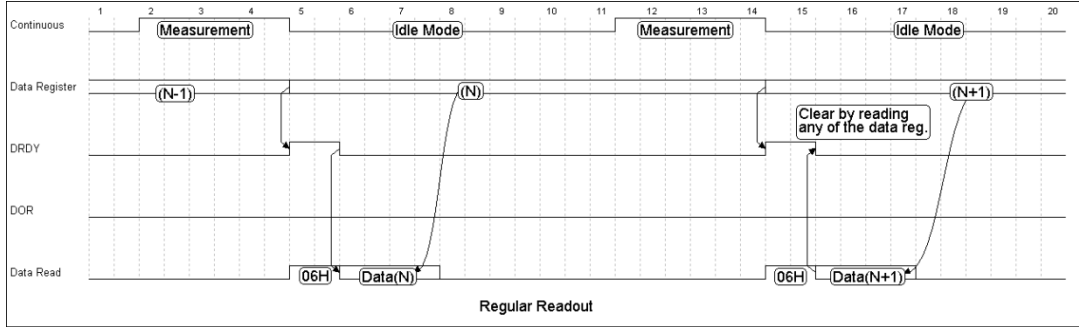

**Figure 10. Normal Read Sequence**

## 6.2.1.2 Data Read Sequence Occurs at Measurement

During measurement, it's possible to read data register which keep the previous measured data. Therefore, no interrupt (DRDY bit) will be set if data reading occurs at the middle of measurement.

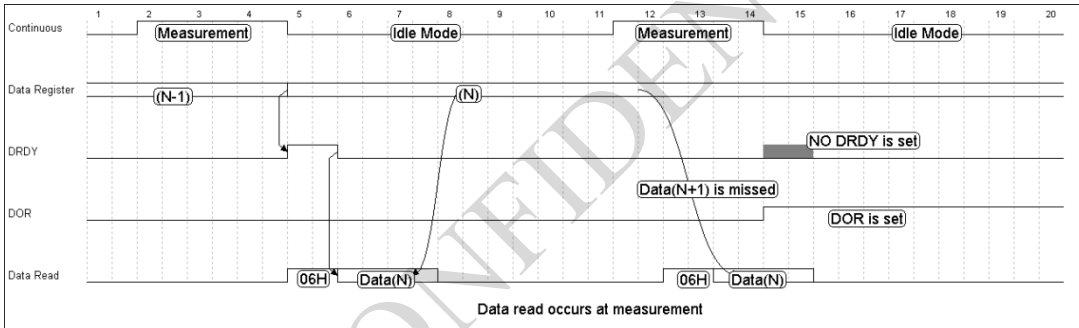

**Figure 11 Data Read Sequence at Measurement**

## 6.2.1.3 Data Not Read

If Nth data is skipped, the current data will be flushed by next coming data. In this case, interrupt (DRDY bit) keeps high until data is read. DOR bit is set to "1" which indicates a set of measurement data has been lost. DOR bit turns to "0" once 06H is accessed in next data read operation

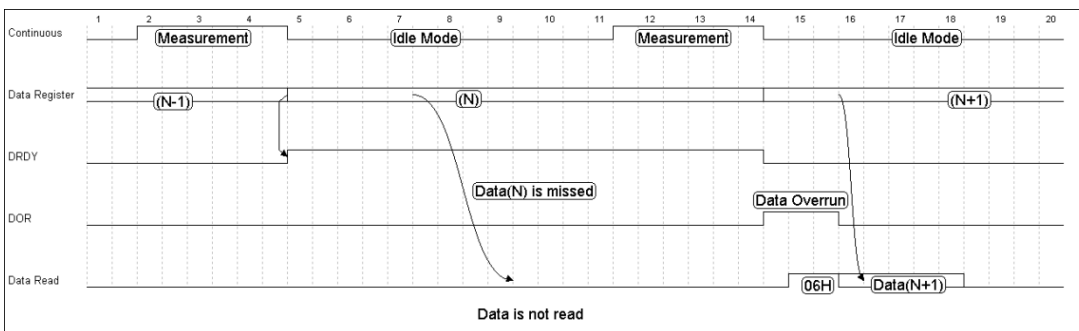

**Figure 12. Sequence When Data Not Read**

#### 6.2.1.4 Data Locks Until Next Measurement Ends

Data lock is activated once any of the data register is accessed. If 05H (data unlock) is not accessed until next measurements ends, current data blocks next data to update data register. In this case, DOR bit is also set to "1" until 06H is accessed in next data read.

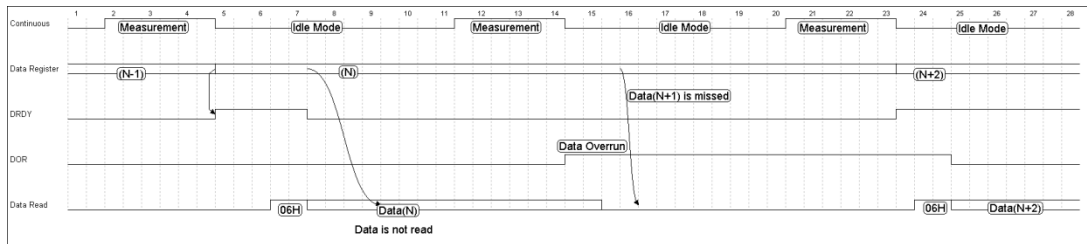

Figure 13. Sequence When Data Locks

#### 6.2.1.5 Interrupt

An interrupt is generated on INT pin each time that magnetic field is measured. The interrupt can be disabled by set 0AH[0] = 1.

#### 6.2.2 Standby Mode

Standby mode is the default state of QMC6983 upon POR and soft reset, only few function blocks are activated in this mode, which keeps power consumption as low as possible. In this state, register values are hold on by an ultra-low power LDO, I<sup>2</sup>C interface can be woken up by reading or writing any registers. There is no magnetometer measurement in the Standby mode. Internal clocking is also halted.

#### 6.2.3 Self-Test Mode

To check the QMC6983 for proper operation, a self-test feature is incorporated in which the sensor is internally excited with a nominal magnetic field, This field is then measured and reported. This function is enabled by changing register (09H) to mode =10. Then the self-test data can be obtained in the data output registers. By using this built-in function, the manufacturer can quickly verify the sensor's full functionality after the assembly without additional test setup.

## 7 Application Examples

### 7.1 Continuous Mode Setup Example

- ✧ Write Register 0BH by 0xFF (Define Set/Reset period, not recommend to change)
- ✧ Write Register 09H by 0x3D (Define OSR = 512, Full Scale Range = 20 Gauss, ODR = 200Hz, set continuous measurement mode)

### 7.2 Measurement Example

- ✧ Check status register 06H[0] , "1" means ready.
- ✧ Read data register 00H ~ 05H.

### 7.3 Self-test Example

- ✧ Write Register 09H by 0x32 (Full Scale Range = 20 Gauss, not recommend to change)
- ✧ Waiting 3 millisecond until measurement ends
- ✧ Read data Register 00H ~ 05H
- ✧ Check data if within specification

# QMC6983

## 7.4 Standby Example

- ✧ Write Register 09H by 0x00

## 7.5 Soft Reset Example

- ✧ Write Register 0AH by 0x80

# 8 I<sup>2</sup>C COMMUNICATION PROTOCOL

## 8.1 I<sup>2</sup>C Timings

Below table and graph describe the I<sup>2</sup>C communication protocol times

**Table 9. I<sup>2</sup>C Timings**

Parameter	Symbol	Condition	Min.	Typ.	Max.	Unit
SCL Clock	$f_{scl}$		0		400	kHz
SCL Low Period	$t_{low}$		1			$\mu$ S
SCL High Period	$t_{high}$		1			$\mu$ S
SDA Setup Time	$t_{sdata}$		0.1			$\mu$ S
SDA Hold Time	$t_{hdata}$		0		0.9	$\mu$ S
Start Hold Time	$t_{hdsta}$		0.6			$\mu$ S
Start Setup Time	$t_{susta}$		0.6			$\mu$ S
Stop Setup Time	$t_{susto}$		0.6			$\mu$ S
New Transmission Time	$t_{buf}$		1.3			$\mu$ S
Rise Time	$t_r$					$\mu$ S
Fall Time	$t_f$					$\mu$ S

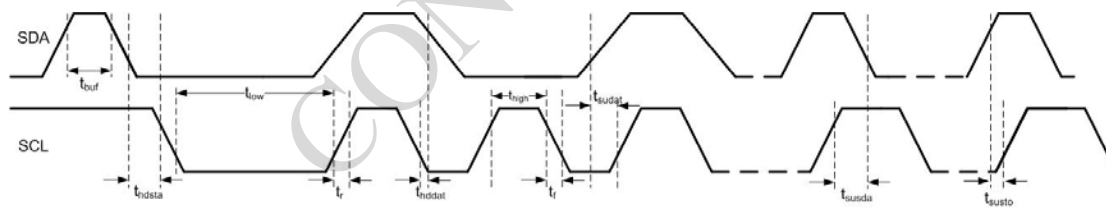

I<sup>2</sup>C Timing Diagram

**Figure 14. I<sup>2</sup>C Timing Diagram**

## 8.2 I<sup>2</sup>C R/W Operation

### 8.2.1 Abbreviation

**Table 10. Abbreviation**

SACK	Acknowledged by slave
MACK	Acknowledged by master
NACK	Not acknowledged by master
RW	Read/Write

### 8.2.2 Start/Stop/Ack

START: Data transmission begins with a high to transition on SDA while SCL is held high. Once I<sup>2</sup>C transmission starts, the bus is considered busy.

STOP: STOP condition is a low to high transition on SDA line while SCL is held high.

ACK: Each byte of data transferred must be acknowledged. The transmitter must release the SDA line during the acknowledge pulse while the receiver must then pull the SDA line low so that it remains stable low during the high period of the acknowledge clock cycle.

NACK: If the receiver doesn't pull down the SDA line during the high period of the acknowledge clock cycle, it's recognized as NACK by the transmitter.

### 8.2.3 I<sup>2</sup>C Write

I<sup>2</sup>C write sequence begins with start condition generated by master followed by 7 bits slave address and a write bit (RW=0). The slave sends an acknowledge bit (ACK=0) and releases the bus. The master sends the one byte register address. The slave again acknowledges the transmission and waits for 8 bits data which shall be written to the specified register address. After the slave acknowledges the data byte, the master generates a stop signal and terminates the writing protocol.

**Table 11. I<sup>2</sup>C Write**

START	Slave Address							R W	SACK	Register Address (0x09)							SACK	Data (0x01)								SACK	STOP
	0	0	0	1	1	0	0	0		0	0	0	0	1	0	0		1	0	0	0	0	0	0	0		

### 8.2.4 I<sup>2</sup>C Read

I<sup>2</sup>C write sequence consists of a one-byte I<sup>2</sup>C write phase followed by the I<sup>2</sup>C read phase. A start condition must be generated between two phase. The I<sup>2</sup>C write phase addresses the slave and sends the register address to be read. After slave acknowledges the transmission, the master generates again a start condition and sends the slave address together with a read bit (RW=1). Then master releases the bus and waits for the data bytes to be read out from slave. After each data byte the master has to generate an acknowledge bit (ACK = 0) to enable further data transfer. A NACK from the master stops the data being transferred from the slave. The slave releases the bus so that the master can generate a STOP condition and terminate the transmission.

The register address is automatically incremented and more than one byte can be sequentially read out. Once a new data read transmission starts, the start address will be set to the register address specified in the current I<sup>2</sup>C write command.

**Table 12. I<sup>2</sup>C Read**

START	Slave Address							R W	SACK	Register Address (0x09)							SACK									
	0	0	0	1	1	0	0	0		0	0	0	0	1	0	0		1								
START	Slave Address							R W	SACK	Register Address (0x09)							MACK	Data (0x01)								
	0	0	0	1	1	0	0	1		0	0	0	0	1	0	0		1	0	0	0	0	0	0	0	1
MACK	Data (0x02)							MACK	..... ..... .....							MACK	Data (0x07)								MACK	STOP
	0	0	0	0	0	0	1		0	0	0	0	0	1	1		1	0	0	0	0	0	1	1		

### 8.2.5 I<sup>2</sup>C Pointer Roll-over

QMC6983 has an embedded I<sup>2</sup>C pointer roll-over function which can improve the data transmission efficiency. The I<sup>2</sup>C data pointer will automatically roll between 00H ~ 06H if I<sup>2</sup>C read begins at any position among 00H~06H. This function is enabled by set 0AH[6] = 01H.

## 9 REGISTERS

### 9.1 Register Map

The table below provides a list of the 8-bit registers embedded in the device and their respective function and addresses

**Table 13. Register Map**

Addr.	7	6	5	4	3	2	1	0	Access
00H	Data Output X LSB Register XOUT[7:0]								Read only
01H	Data Output X MSB Register XOUT[15:8]								Read only
02H	Data Output Y LSB Register YOUT[7:0]								Read only
03H	Data Output Y MSB Register YOUT[15:8]								Read only
04H	Data Output Z LSB Register ZOUT[7:0]								Read only
05H	Data Output Z MSB Register ZOUT[15:8]								Read only
06H						DOR	OVL	DRD Y	Read only
07H	TOUT[7:0]								Read only
08H	TOUT[15:8]								Read only
09H	OSR[1:0]		RNG[1:0]		ODR[1:0]		MODE[1:0]		Read/Write
0AH	SOFT_ RST	ROL_P NT		LFSR_ START				INT_ ENB	R/W, Read only on blanks
0BH	SET/RESET Period FBR [7:0]								Read/Write
0CH	Reserved								Read only
0DH	Reserved								Read only
0EH- 11H	Encryption								Read/Write

### 9.2 Register Definition

#### 9.2.1 Output Data Register

Registers 00H ~ 05H store the measurement data from each axis magnetic sensor in continuous-measurement or self-test modes. In the continuous measurement mode, the output data is refreshed periodically based on the data update rate ODR setup in control registers 1. The data stays the same, regardless of reading status through I<sup>2</sup>C, until new data replaces them. Each axis has 16 bit data width in 2's complement, i.e., MSB of 01H/03H/05H indicates the sign of each axis. The output data of each channel saturates at -32768 and 32767.

**Table 14. Output Data Register**

Addr.	7	6	5	4	3	2	1	0
00H	Data Output X LSB Register XOUT[7:0]							
01H	Data Output X MSB Register XOUT[15:8]							
02H	Data Output Y LSB Register YOUT[7:0]							
03H	Data Output Y MSB Register YOUT[15:8]							
04H	Data Output Z LSB Register ZOUT[7:0]							
05H	Data Output Z MSB Register ZOUT[15:8]							

#### 9.2.2 Status Register

There are two status registers located in address 06H and 0CH.

Register 06H has three bits indicating for status flags, the rest are reserved for factory use. The status registers are read only bits.



**Table 15. Status Register 1**

Addr.	7	6	5	4	3	2	1	0
06H						DOR	OVL	DRDY

Data Ready Register (DRDY), it is set when all three axis data is ready, and loaded to the output data registers in the continuous measurement mode or in the self-test mode. It is reset to “0” by reading any data register (00H–05H) through I<sup>2</sup>C commands

DRDY: “0”: no new data, “1”: new data is ready

Overflow flag (OVL) is set to “1” if any data of three axis magnetic sensor channels is out of range. The output data of each axis saturates at -32768 and 32767, if any of the axis exceeds this range, OVL flag is set to “1”. This flag is reset to “0” if next measurement goes back to the range of (-32768, 32767), otherwise, it keeps as “1”.

OVL: “0”: normal, “1”: data overflow

Data Skip (DOR) bit is set to “1” if all the channels of output data registers are skipped in reading in the continuous-measurement mode. It is reset to “0” by reading any data register (00H–05H) through I<sup>2</sup>C

DOR: “0”: normal, “1”: data skipped for reading

### 9.2.3 Temperature Data Registers

Registers 07H-08H store temperature sensor output data. 16 bits temperature sensor output is in 2’s complement. Temperature sensor gain is factory-calibrated, but its offset has not been compensated, only relative temperature value is accurate. The temperature coefficient is about 100 LSB/°C

**Table 17. Temperature Sensor Output**

Addr.	7	6	5	4	3	2	1	0
07H	TOUT[7:0]							
08H	TOUT[15:8]							

### 9.2.4 Control Registers

Two 8-bits registers are used to control the device configurations.

Control register 1 is located in address 09H, it sets the operational modes (MODE), output data update rate (ODR), magnetic field measurement range or sensitivity of the sensors (RNG) and over sampling rate (OSR).

Control register 2 is located in address 0AH. It controls Interrupt Pin enabling (INT\_ENB), Point roll over function enabling (POL\_PNT) and soft reset (SOFT\_RST).

Two bits of MODE registers can transfer mode of operations in the device, the three modes are Standby, Continuous measurements and self-test. The default mode after Power-on-Reset (POR) is standby. There is no any restriction in the transferring among the three modes.

Output data rate is controlled by ODR registers. Four data update frequencies can be selected: 10Hz, 50Hz, 100Hz and 200Hz. For most of compassing applications, we recommend 10 Hz for low power consumption. For gaming, the high update rate such as 100Hz or 200Hz can be used.

Field ranges of the magnetic sensor can be selected through the register RNG. The full scale field range is determined by the application environments. For magnetic clear environment, low field range such as +/- 2gauss can be used. The field range goes hand in hand with the sensitivity of the magnetic sensor. The lowest field range has the highest sensitivity, therefore, higher resolution. Four magnetic field ranges can be selected, 2Gauss, 8 gauss, 12 gauss and 20 gauss.

Over sample Rate (OSR) registers are used to control bandwidth of an internal digital filter. Larger OSR value

## QMC6983

leads to smaller filter bandwidth, less in-band noise and higher power consumption. It could be used to reach a good balance between noise and power. Four over sample ratio can be selected, 64, 128, 256 or 512.

**Table 18. Control Register 1**

Addr	7	6	5	4	3	2	1	0
09H	OSR[1:0]		RNG[1:0]		ODR[1:0]		MODE[1:0]	
<b>Reg.</b>	<b>Definition</b>		<b>00</b>	<b>01</b>	<b>10</b>	<b>11</b>		
Mode	Mode Control		Standby	Continuous	Self-Test	Reserve		
ODR	Output Data Rate		10Hz	50Hz	100Hz	200Hz		
RNG	Full Scale		2G	8G	12G	20G		
OSR	Over	Sample	512	256	128	64		
	Ratio							

Interrupt enabling is controlled by register INT\_ENB in control register 2. Once the interrupt is enabled, it will flag when new data is in Data Output Registers.

INT\_ENB: “0”: enable interrupt PIN, “1”: disable interrupt PIN

Pointer roll-over function is controlled by ROL\_PNT register. When the point roll-over function is enabled, the I<sup>2</sup>C data pointer automatically rolls between 00H ~ 06H, if I<sup>2</sup>C read begins at any address among 00H~06H.

ROL\_PNT: “0”: Normal, “1”: Enable pointer roll-over function

Soft Reset can be done by changing the register SOFT\_RST to set. Soft reset can be invoked at any time of any mode. For example, if soft reset occurs at the middle of continuous mode reading, QMC6983 immediately switches to standby mode due to mode register is reset to “00” in default.

SOFT\_RST: “0”: Normal “1”: Soft reset, restore default value of all registers.

**Table 19. Control Register 2**

Addr.	7	6	5	4	3	2	1	0
0AH	SOFT_RST	ROL_PNT						INT_ENB

### 9.2.5 SET/RESET Period Register

SET/RESET Period is controlled by FBR [7:0], it is recommended that the register 0BH is written by 0xFF, not change to any other value.

**Table 20. SET/RESET Period Register**

Addr.	7	6	5	4	3	2	1	0
0BH	SET/RESET Period FBR [7:0]							

### 9.2.6 Encryption Registers

0EH-11H is used for encryption code.

## ORDERING INFORMATION

Ordering Number	Temperature Range	Package	Packaging
QMC6983-TR	-40°C~85°C	LGA-12	Tape and Reel: 5k pieces/reel

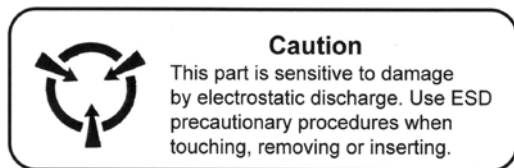

**CAUTION: ESDS CAT. 1B**

### FIND OUT MORE

For more information on QST's Magnetic Sensors contact us at 86-21-50496156.

The application circuits herein constitute typical usage and interface of QST product. QST does not provide warranty or assume liability of customer-designed circuits derived from this description or depiction.

QST reserves the right to make changes to improve reliability, function or design. QST does not assume any liability arising out of the application or use of any product or circuit described herein; neither does it convey any license under its patent rights nor the rights of others.

U.S. Patents 4,441,072, 4,533,872, 4,569,742, 4,681,812, 4,847,584 and 6,529,114 apply to the technology described.

CONFIDENTIAL



QST  
Room 1104, Building No.1,  
Changning Road 865, Shanghai  
Tel: 86-21-50496156

Rev 1.1-NCP, released Sept. 2013  
QST Corporation